

LEGAL DESCRIPTION

(PER CHICAGO TITLE COMPANY PRELIMINARY REPORT ORDER NO. 0000084196-894-L72-DB DATED JANUARY 29, 2018)

THE LAND REFERRED TO HEREIN BELOW IS SITUATED IN THE CITY OF LOS ANGELES, IN THE COUNTY OF LOS ANGELES, STATE OF CALIFORNIA, AND IS DESCRIBED AS FOLLOWS:

PARCEL A: (PORTION OF 5546-030-028)

THAT PORTION OF LOT 1 OF TRACT NO. 18237, IN THE CITY OF LOS ANGELES, COUNTY OF LOS ANGELES, STATE OF CALIFORNIA, AS PER MAP RECORDED IN BOOK 529, PAGES 10 AND 11 OF MAPS, IN THE OFFICE OF THE COUNTY RECORDER OF SAID COUNTY, LYING WESTERLY OF A LINE WHICH IS PARALLEL, WITH AND DISTANT 260.00 FEET EASTERLY, MEASURED AT RIGHT ANGLES, FROM THE CENTER LINE OF VINE STREET, 100 FEET WIDE, AS SHOWN ON THE MAP OF SAID TRACT.

EXCEPT THAT PORTION OF SAID LAND LYING SOUTHERLY OF A LINE WHICH IS PARALLEL WITH THE MOST SOUTHERLY LINE OF SAID LOT 1 AND DISTANT 119.96 FEET NORTHERLY THEREFROM, MEASURED AT RIGHT ANGLES.

PARCEL B: (REMANDER OF 5546-030-028)

THE SOUTH 58 FEET OF LOT 12 OF CENTRAL HOLLYWOOD TRACT NO. 2, IN THE CITY OF LOS ANGELES, COUNTY OF LOS ANGELES, STATE OF CALIFORNIA, AS PER MAP RECORDED IN BOOK 6, PAGE 144 OF MAPS, IN THE OFFICE OF THE COUNTY RECORDER OF SAID COUNTY.

PARCEL C: (5546-030-031)

THE EAST 50 FEET OF THE NORTH 2 FEET OF LOT 12 OF CENTRAL HOLLYWOOD TRACT NO. 2, AND THE EAST 50 FEET OF LOT 13 OF SAID CENTRAL HOLLYWOOD TRACT NO. 2, WITH THE EXCEPTION OF THAT PORTION DEEDED TO THE CITY FOR STREET PURPOSES OF LOS ANGELES, IN THE CITY OF LOS ANGELES, COUNTY OF LOS ANGELES, STATE OF CALIFORNIA, AS PER MAP RECORDED IN BOOK 6, PAGE 144 OF MAPS, IN THE OFFICE OF THE COUNTY RECORDER OF SAID COUNTY.

PARCEL D: (5546-030-032)

THE WEST 100 FEET OF LOTS 12 AND 13 OF CENTRAL HOLLYWOOD TRACT NO. 2, IN THE CITY OF LOS ANGELES, COUNTY OF LOS ANGELES, STATE OF CALIFORNIA, AS PER MAP RECORDED IN BOOK 6, PAGE 144 OF MAPS, IN THE OFFICE OF THE COUNTY RECORDER OF SAID COUNTY.

EXCEPT THE SOUTH 58 FEET OF SAID LOT 12.

ALSO EXCEPT THEREFROM THAT PORTION OF SAID LAND INCLUDED WITHIN THE LINES OF YUCCA STREET AS DESCRIBED IN LOS ANGELES COUNTY SUPERIOR COURT CASE NO. 202250, NOTICE OF PENDENCY OF SAID ACTION WAS RECORDED ON AUGUST 06, 1926 AS INSTRUMENT NO. 1775, IN BOOK 6018, PAGE 270 OF OFFICIAL RECORDS, IN SAID OFFICE OF THE COUNTY RECORDER.

SAID PROPERTY IS ALSO KNOWN AS AND IS DESCRIBED AS A WHOLE AS FOLLOWS:

BEGINNING AT THE MOST WESTERLY CORNER OF LOT 1, TRACT NO. 18237, AS PER MAP RECORDED IN BOOK 529, PAGES 10 AND 11 OF MAPS, IN THE OFFICE OF THE COUNTY RECORDER OF LOS ANGELES COUNTY, CALIFORNIA, SAID POINT BEING ON THE EASTERLY RIGHT OF WAY OF VINE STREET 100 FEET WIDE, THENCE NORTH 07°15'20" WEST 119.96 FEET TO THE TRUE POINT OF BEGINNING, THENCE CONTINUING NORTH 07°15'20" WEST 297.05 FEET; THENCE NORTH 89°52'48" EAST 150.02 FEET; THENCE SOUTH 07°15'20" EAST 24.00 FEET TO THE SOUTHERLY RIGHT OF WAY OF YUCCA STREET 94 FEET WIDE; THENCE NORTH 89°52'48" EAST 59.95 FEET; THENCE SOUTH 07°15'20" EAST 272.10 FEET; THENCE SOUTH 89°37'21" WEST 27.30 FEET TO A POINT WHICH IS 232.67 FEET PARALLEL, WITH AND EASTERLY OF THE CENTERLINE OF VINE STREET 100 FEET WIDE; THENCE SOUTH 89°37'21" WEST 182.67 FEET TO THE POINT OF BEGINNING.

PARCEL E:

A NON-EXCLUSIVE EASEMENT FOR PARKING SPACES AS SET FORTH IN THAT CERTAIN UNRECORDED PARKING EASEMENT AGREEMENT DATED AS OF MARCH 27, 2001, SUBJECT TO THE TERMS THEREIN PROVIDED, AS DISCLOSED BY THAT CERTAIN INSTRUMENT ENTITLED "MEMORANDUM OF PARKING EASEMENT AGREEMENT" RECORDED MARCH 30, 2001 AS INSTRUMENT NO. 01-528743, OFFICIAL RECORDS, AND SUBJECT TO THE TERMS AND PROVISIONS OF THAT CERTAIN "SUBORDINATION, NON-DISTURBANCE AND ATTORNEYS AGREEMENT" RECORDED MARCH 30, 2001 AS INSTRUMENT NO. 01-528748 OF OFFICIAL RECORDS, SAID PARKING SPACES ARE LOCATED ON THE PROPERTY DESCRIBED IN EXHIBIT "B" ATTACHED TO SAID MEMORANDUM OF PARKING EASEMENT AGREEMENT.

PARCEL F: (5546-004-020; 5546-004-021)

LOTS 20, 21 AND THOSE PORTIONS OF LOTS 19 AND 22 IN BLOCK 21 OF HOLLYWOOD, IN THE CITY OF LOS ANGELES, COUNTY OF LOS ANGELES, STATE OF CALIFORNIA, AS PER MAP RECORDED IN BOOK 28, PAGES 59 AND 60 OF MISCELLANEOUS RECORDS, IN THE OFFICE OF THE COUNTY RECORDER OF SAID COUNTY, DESCRIBED AS FOLLOWS:

BEGINNING AT A POINT IN THE EAST LINE OF SAID LOT 19, DISTANT NORTHERLY THEREON, 400.23 FEET FROM THE NORTH LINE OF HOLLYWOOD BOULEVARD, 100.00 FEET WIDE, AS ESTABLISHED BY SAID CITY, MEASURED ALONG THE EASTERLY LINES OF LOTS 13 TO 19 INCLUSIVE IN SAID BLOCK 21; THENCE WESTERLY IN A DIRECT LINE, A DISTANCE OF 181.50 FEET TO A POINT IN THE WEST LINE OF SAID LOT 19, DISTANT NORTHERLY THEREON 400.39 FEET, MEASURED ALONG THE WESTERLY LINE OF SAID LOT 13 TO 19 INCLUSIVE OF SAID BLOCK FROM THE NORTHERLY LINE OF SAID HOLLYWOOD BOULEVARD ALONG THE WESTERLY LINES OF SAID LOTS 19, 20, 21 AND 22; THENCE NORTH 07°15'20" WESTERLY 17.00 FEET OF SAID LOT 22; THENCE EASTERLY ALONG SAID NORTHERLY LINE TO THE EASTERLY LINE OF SAID LOT 22; THENCE SOUTHERLY ALONG THE EASTERLY LINES OF SAID LOTS 22, 21, 20 AND 19 TO THE POINT OF BEGINNING.

PARCEL G: (5546-004-006)

LOTS 3, 4 AND THOSE PORTIONS OF LOTS 2 AND 5 IN BLOCK 21 OF HOLLYWOOD, IN THE CITY OF LOS ANGELES, COUNTY OF LOS ANGELES, STATE OF CALIFORNIA, AS PER MAP RECORDED IN BOOK 28, PAGES 59 AND 60 OF MISCELLANEOUS RECORDS, IN THE OFFICE OF THE COUNTY RECORDER OF SAID COUNTY, DESCRIBED AS A WHOLE AS FOLLOWS:

BEGINNING AT THE INTERSECTION OF THE NORTHERLY LINE OF THE SOUTH 16.80 FEET OF SAID LOT 5 WITH THE EASTERLY LINE THEREOF; THENCE WESTERLY ALONG SAID NORTHERLY LINE TO THE WESTERLY LINE OF SAID LOT 5; THENCE NORTHERLY ALONG THE WESTERLY LINES OF SAID LOTS 5, 4, 3 AND 2 OF SAID BLOCK TO THE NORTHERLY LINE OF THE SOUTHERLY 9.80 FEET OF SAID LOT 2; THENCE EASTERLY ALONG SAID NORTHERLY LINE TO THE EASTERLY LINE OF SAID LOT 2; THENCE SOUTHERLY ALONG THE EASTERLY LINES OF SAID LOTS 2, 3, 4 AND 5 TO THE POINT OF BEGINNING.

PARCEL H: (5546-004-029; 5546-004-032)

THOSE PORTIONS OF LOTS 1 AND 2 IN BLOCK 21 OF HOLLYWOOD, IN THE CITY OF LOS ANGELES, AS PER MAP RECORDED IN BOOK 28, PAGES 59 AND 60 OF MISCELLANEOUS RECORDS, IN THE OFFICE OF THE COUNTY RECORDER OF SAID COUNTY, DESCRIBED AS A WHOLE AS FOLLOWS:

BEGINNING AT THE NORTHWESTERLY CORNER OF SAID LOT 2, WHICH IS A POINT IN THE EAST LINE OF IVAR AVENUE (70 FEET WIDE); THENCE ALONG THE WEST LINE OF SAID LOT 1 NORTH 09°05'30" EAST 5.31 FEET, MORE OR LESS, TO THE SOUTHERLY LINE OF YUCCA STREET, AS DESCRIBED IN PARCEL 17 OF DECEMBER 17, 1929 AS INSTRUMENT NO. 202-550 OF THE SUPERIOR COURT OF SAID COUNTY, AS CERTIFIED COPY OF SAID DECREE BEING RECORDED ON OCTOBER 18, 1929 AS INSTRUMENT NO. 1085, IN BOOK 9421, PAGE 173 OF OFFICIAL RECORDS, IN THE OFFICE OF SAID RECORDER; THENCE ALONG SAID YUCCA STREET NORTH 83°32'16" EAST 13.28 FEET AND SOUTH 82°28'58" EAST 122.48 FEET, MORE OR LESS, TO THE WEST LINE OF THE EAST 50.00 FEET OF SAID LOTS 1 AND 2; THENCE SOUTHERLY ALONG THE LAST MENTIONED WEST LINE 54.50 FEET, MORE OR LESS, TO THE NORTH LINE OF THE SOUTH 9.80 FEET OF SAID LOT 2; THENCE WESTERLY ALONG SAID NORTH LINE 131.50 FEET TO THE WEST LINE OF SAID LOT 2; THENCE ALONG SAID WEST LINE 55.20 FEET, MORE OR LESS, TO THE POINT OF BEGINNING.

PARCEL I:

PARCEL 1: (APN: 5546-030-033)

THAT PORTION OF LOT 1 OF TRACT NO. 18237, IN THE CITY OF LOS ANGELES, COUNTY OF LOS ANGELES, STATE OF CALIFORNIA, AS PER MAP RECORDED IN BOOK 529 PAGES 10 AND 11 OF MAPS, IN THE OFFICE OF THE COUNTY RECORDER OF SAID COUNTY, DESCRIBED AS FOLLOWS:

BEGINNING AT THE MOST WESTERLY SOUTHWEST CORNER OF SAID LOT; THENCE NORTHERLY ALONG THE WESTERLY LINE OF SAID LOT TO A LINE WHICH IS PARALLEL, WITH AND SOUTHERLY OF SAID LOT 1 AND DISTANT 119.96 FEET NORTHERLY THEREFROM MEASURED AT RIGHT ANGLES, TO SAID SOUTHERLY LINE; THENCE EASTERLY ALONG SAID LAST MENTIONED PARALLEL LINE TO A LINE WHICH IS PARALLEL WITH AND DISTANT 260.00 FEET EASTERLY MEASURED AT RIGHT ANGLES FROM THE CENTER LINE OF VINE STREET, 100 FEET WIDE, AS SHOWN ON THE MAP OF SAID TRACT NO. 18237; THENCE NORTHERLY ALONG SAID LAST MENTIONED PARALLEL LINE TO A POINT IN THE NORTHERLY LINE OF SAID LOT 1; THENCE NORTH 89° 52' 27" EAST ALONG SAID LAST MENTIONED NORTHERLY LINE TO THE EASTERLY TERMINUS OF THAT CERTAIN COURSE IN THE NORTHERLY LINE OF SAID LOT SHOWN ON THE MAP OF SAID TRACT AS HAVING A BEARING AND LENGTH OF SOUTH 89° 52' 27" WEST 195.04 FEET; THENCE SOUTHERLY ALONG A TANGENT CURVE TO THE BOUNDARY LINE OF SAID LOT CONCAVE TO THE SOUTHWEST HAVING A RADIUS OF 14.49 FEET AND AN ARC LENGTH OF 23.51 FEET TO THE END THEREOF; THENCE SOUTH 0° 16' 00" EAST ALONG THE EASTERLY LINE OF SAID LOT, TO A POINT 171.50 FEET, NORTHERLY MEASURED ALONG SAID EASTERLY LINE FROM THE SOUTHEASTERLY CORNER OF SAID LOT, SAID POINT BEING THE TRUE POINT OF BEGINNING OF THIS DESCRIPTION; THENCE SOUTH 0° 16' 00" EAST ALONG SAID EASTERLY LINE 171.50 FEET TO THE SOUTHEASTERLY CORNER OF SAID LOT; THENCE SOUTH 89° 37' 45" WEST 109.50 FEET ALONG THE SOUTHERLY LINE OF SAID LOT TO AN ANGLE POINT THEREIN; THENCE CONTINUING ALONG SAID SOUTHERLY LINE NORTH 48° 55' 41" WEST 30.21 FEET TO AN ANGLE POINT THEREIN; THENCE SOUTH 89° 37' 45" WEST ALONG THE SOUTHERLY LINE OF SAID LOT AND ITS WESTERLY PROLONGATION SHOWN ON SAID MAP AS HAVING A BEARING OF SOUTH 89° 37' 45" WEST AND A LENGTH OF 39.82 FEET TO A LINE WHICH IS PARALLEL, WITH AND DISTANT 232.67 FEET EASTERLY MEASURED AT RIGHT ANGLES FROM THE CENTER LINE OF VINE STREET ABOVE DESCRIBED; THENCE NORTHERLY ALONG SAID LAST MENTIONED PARALLEL LINE TO A POINT ON THE LINE ABOVE DESCRIBED AS BEING PARALLEL, WITH THE MOST SOUTHERLY LINE OF SAID LOT; THENCE EASTERLY ALONG SAID LINE TO THE LINE ABOVE DESCRIBED AS BEING PARALLEL, WITH AND DISTANT 260.00 FEET EASTERLY OF THE CENTER LINE OF VINE STREET; THENCE NORTHERLY ALONG SAID PARALLEL LINE TO THE INTERSECTION WITH A LINE PERPENDICULAR TO THE LINE ABOVE DESCRIBED AS THE EASTERLY LINE OF SAID LOT AT THE TRUE POINT OF BEGINNING; THENCE NORTH 89° 44' EAST ALONG SAID PERPENDICULAR LINE TO THE TRUE POINT OF BEGINNING.

SAID LAND IS ALSO KNOWN AS:

BEGINNING AT THE MOST WESTERLY CORNER OF LOT 1, TRACT NO. 18237, AS PER MAP RECORDED IN BOOK 529 PAGES 10 AND 11 OF MAPS, IN THE OFFICE OF THE COUNTY RECORDER OF SAID COUNTY CALIFORNIA, SAID POINT BEING ON THE EASTERLY RIGHT OF WAY OF VINE STREET 100' WIDE; THENCE N00 DEGREES 15'52"W 119.96'; THENCE N89 DEGREES 37'21"E 182.67' TO THE TRUE POINT OF BEGINNING, THENCE; N89 DEGREES 37'21"E 27.30'; THENCE N00 DEGREES 15'52"W 101.80'; THENCE N89 DEGREES 44'08"E 150.07' TO THE WESTERLY RIGHT OF WAY OF ARGYLE AVENUE 75' WIDE; THENCE SOUTHERLY ALONG SAID RIGHT OF WAY; S80 DEGREES 15'48"E 171.50' TO THE NORTHERLY RIGHT OF WAY OF A PUBLICLY DEDICATED ALLEY WAY BEING 20' WIDE THENCE ALONG SAID RIGHT OF WAY; S89 DEGREES 37'21"W 109.50' THENCE; N48 DEGREES 56'05"W 30.22' THENCE; S89 DEGREES 37'21"W 45.18' TO A POINT WHICH BEARS S00 DEGREES 15'52"E FROM THE POINT OF BEGINNING OF THIS DESCRIPTION; THENCE N00 DEGREES 15'52"E 49.99' RETURNING TO THE POINT OF BEGINNING.

PARCEL 2:

A NON-EXCLUSIVE EASEMENT FOR PARKING SPACES AS SET FORTH IN THAT CERTAIN UNRECORDED PARKING EASEMENT AGREEMENT DATED AS OF MARCH 27, 2001, SUBJECT TO THE TERMS THEREIN PROVIDED, AS DISCLOSED BY THAT CERTAIN INSTRUMENT ENTITLED "MEMORANDUM OF PARKING EASEMENT AGREEMENT" RECORDED MARCH 30, 2001 AS INSTRUMENT NO. 01-528743, OFFICIAL RECORDS, AND SUBJECT TO THE TERMS AND PROVISIONS OF THAT CERTAIN "SUBORDINATION, NON-DISTURBANCE AND ATTORNEYS AGREEMENT" RECORDED MARCH 30, 2001 AS INSTRUMENT NO. 01-528748 OF OFFICIAL RECORDS, SAID PARKING SPACES ARE LOCATED ON THE PROPERTY DESCRIBED IN EXHIBIT "B" ATTACHED TO SAID MEMORANDUM OF PARKING EASEMENT AGREEMENT.

PARCEL 3: (APN 5546-030-034)

THOSE PORTIONS OF LOT 1 OF TRACT NO. 18237, IN THE CITY OF LOS ANGELES, COUNTY OF LOS ANGELES, STATE OF CALIFORNIA, AS PER MAP RECORDED IN BOOK 529 PAGES 10 AND 11 OF MAPS, IN THE OFFICE OF THE COUNTY RECORDER OF SAID COUNTY, AND LOT 6 OF CENTRAL HOLLYWOOD TRACT NO. 2, IN THE CITY OF LOS ANGELES, COUNTY OF LOS ANGELES, STATE OF CALIFORNIA, AS PER MAP RECORDED IN BOOK 6 PAGE 144 OF MAPS, IN THE OFFICE OF THE COUNTY RECORDER OF SAID COUNTY, DESCRIBED AS FOLLOWS:

BEGINNING AT THE SOUTHWEST CORNER OF LOT 6 OF THE CENTRAL HOLLYWOOD TRACT NO. 2, PER MAP RECORDED IN BOOK 6 PAGE 144 OF MAPS, IN THE OFFICE OF THE COUNTY RECORDER OF SAID COUNTY; THENCE ALONG THE SOUTHERLY BOUNDARY OF SAID LOT 6, NORTH 89° 37' 45" EAST 153.00 FEET, MORE OR LESS, TO THE WESTERLY LINE OF THE EASTERLY 87.00 FEET OF SAID LOT 6; THENCE NORTH 0° 15' 52" WEST 60.00 FEET TO THE SOUTHERLY LINE OF LOT 1 OF TRACT NO. 18237, PER MAP RECORDED IN BOOK 529, PAGES 10 AND 11, OF MAPS, IN THE OFFICE OF THE COUNTY RECORDER OF SAID COUNTY; THENCE ALONG THE BOUNDARY OF SAID LOT 1, NORTH 89° 37' 45" EAST 57.00 FEET, NORTH 0° 16' 00" WEST 30.00 FEET, SOUTH 89° 37' 45" WEST 22.03 FEET, AND NORTH 0° 22' 15" WEST 40.00 FEET; THENCE SOUTH 89° 37' 45" WEST 5.22 FEET, MORE OR LESS, ALONG THE SOUTHERLY PROLONGATION OF A COURSE IN THE SOUTHERLY BOUNDARY OF SAID LOT 1, TO A LINE WHICH IS PARALLEL WITH AND DISTANT 232.67 FEET EASTERLY MEASURED AT RIGHT ANGLES FROM THE CENTERLINE OF VINE STREET (100 FEET WIDE); THENCE NORTH 0° 15' 52" WEST 49.97 FEET TO A POINT ALONG SAID PARALLEL LINE TO A LINE WHICH IS PARALLEL, WITH AND 119.96 FEET NORTHERLY MEASURED AT RIGHT ANGLES, FROM THE MOST SOUTHERLY BOUNDARY LINE OF SAID LOT 1; THENCE SOUTH 89° 37' 45" WEST 182.67 FEET TO THE EAST LINE OF VINE STREET; THENCE SOUTH 0° 15' 52" EAST 179.96 FEET TO THE POINT OF BEGINNING.

SAID LAND IS SHOWN ON THAT CERTAIN CERTIFICATE OF COMPLIANCE RECORDED MARCH 30, 2001 AS INSTRUMENT NO. 01-528740

BASIS OF BEARINGS

THE BEARING N00°16'00"W ALONG THE CENTERLINE OF VINE STREET AS SHOWN AS N00°16'00"W ON TRACT 060544 IN BOOK 1325, PAGES 54 AND 55 OF MAPS IN THE COUNTY OF LOS ANGELES, STATE OF CALIFORNIA.

BENCHMARK

ELEVATIONS SHOWN HEREON ARE RELATIVE TO THE FOLLOWING BENCHMARK:

#12-20689: LA CITY PBM #12-20698 1986, 1FT N/O N CURB YUCCA ST 3FT E/O BOR E/O VINE ST W/S CS

ELEV. = 400.846 FT, NGVD 1929, RECORDED 1985

SITE AREA

TOTAL EXISTING PROPERTY AREA: 194,495 SQ.FT OR 4.465 ACRES, MORE OR LESS

TOTAL PROPOSED SIDEWALK EASEMENT AREA: 5,163 SQ. FT. OR 0.119 ACRES, MORE OR LESS

TOTAL PROPOSED ALLEY MERGER AREA: 1,267 SQ. FT. OR 0.029 ACRES, MORE OR LESS

GROSS AREA TO STREET CENTERLINES: 290,044 SQ. FT. OR 6.659 ACRES, MORE OR LESS

VESTING TENTATIVE TRACT MAP NO. 82152 FOR MERGER, SUBDIVISION AND CONDOMINIUM PURPOSES 1,005 RESIDENTIAL UNITS AND 30,177 SQUARE FEET OF COMMERCIAL SPACE

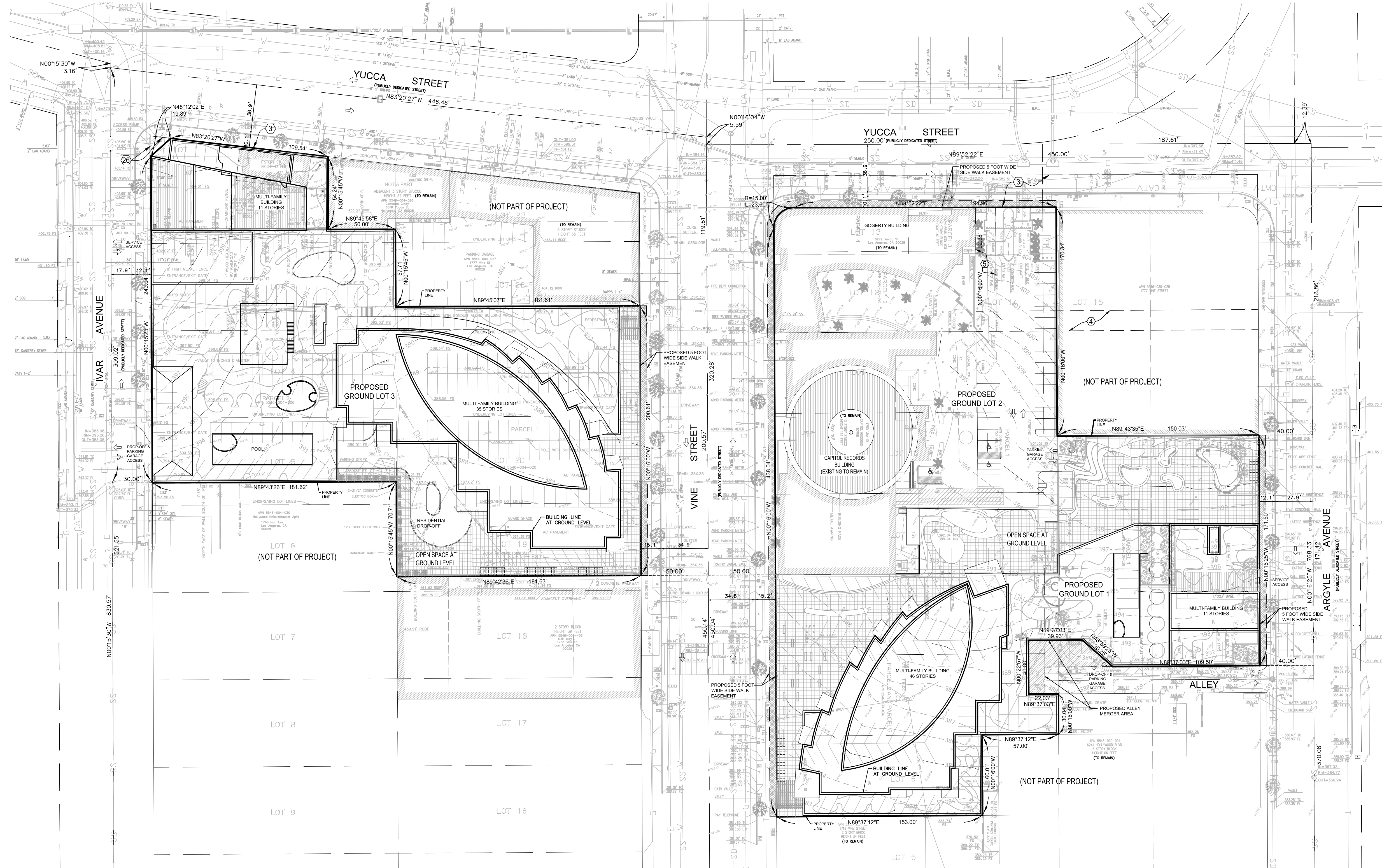

EXCEPTIONS

(PER CHICAGO TITLE COMPANY PRELIMINARY REPORT ORDER NO. 0000084196-894-L72-DB DATED JANUARY 29, 2018)

THE FOLLOWING MATTERS AFFECT PARCELS A, B, C, D & E:

3) EASEMENT(S) FOR THE PURPOSE(S) SHOWN BELOW AND RIGHTS INCIDENTAL THERETO, AS GRANTED IN A DOCUMENT:

PURPOSE: PUBLIC STREET AND HIGHWAY
RECORDING DATE: OCTOBER 18, 1929
RECORDING NO.: 1085, IN BOOK 9421, PAGE 173, OFFICIAL RECORDS
AFFECTS: A PORTION OF SAID LAND.

4) EASEMENT(S) FOR THE PURPOSE(S) SHOWN BELOW AND RIGHTS INCIDENTAL THERETO, AS GRANTED IN A DOCUMENT:

PURPOSE: PUBLIC UTILITIES
RECORDING DATE: MAY 16, 1955
RECORDING NO.: 2621, OFFICIAL RECORDS
AFFECTS: A PORTION OF SAID LAND.

5) EASEMENT(S) FOR THE PURPOSE(S) SHOWN BELOW AND RIGHTS INCIDENTAL THERETO, AS GRANTED IN A DOCUMENT:

PURPOSE: PUBLIC UTILITIES
RECORDING DATE: JUNE 31, 1987
RECORDING NO.: 3761, OFFICIAL RECORDS
AFFECTS: A PORTION OF SAID LAND.

8. COVENANT AND AGREEMENT WHEREIN THE OWNERS AGREE TO HOLD SAID LAND AS ONE PARCEL AND NOT TO SELL ANY PORTION THEREOF SEPARATELY. SAID COVENANT IS EXPRESSED TO RUN WITH THE LAND AND BE BINDING UPON FUTURE OWNERS.

RECORDING DATE: DECEMBER 18, 2000
RECORDING NO.: 00-1966012, OFFICIAL RECORDS
REFERENCE IS MADE TO SAID DOCUMENT FOR FULL PARTICULARS.

MATTERS AFFECTING PARCELS A, B, C, D & E NOT LISTED HEREON ARE NOT EASEMENT ITEMS AND/OR ARE BLANKET IN NATURE

THE FOLLOWING MATTERS AFFECT PARCELS F & G:

22. COVENANT AND AGREEMENT WHEREIN THE OWNERS AGREE TO HOLD SAID LAND AS ONE PARCEL AND NOT TO SELL ANY PORTION THEREOF SEPARATELY. SAID COVENANT IS EXPRESSED TO RUN WITH THE LAND AND BE BINDING UPON FUTURE OWNERS.

RECORDING DATE: FEBRUARY 23, 2001
RECORDING NO.: 01-0307395, OFFICIAL RECORDS
REFERENCE IS HEREBY MADE TO SAID DOCUMENT FOR FULL PARTICULARS.

MATTERS AFFECTING PARCELS F & G NOT LISTED HEREON ARE NOT EASEMENT ITEMS AND/OR ARE BLANKET IN NATURE

THE FOLLOWING MATTERS AFFECT PARCEL H:

26) AN IRREVOCABLE OFFER TO DEDICATE AN EASEMENT OVER A PORTION OF SAID LAND FOR

PURPOSE(S): FUTURE STREET
RECORDING DATE: JULY 14, 1987
RECORDING NO.: 87-1112294 OF OFFICIAL RECORDS

AFFECTS: PORTIONS OF THE LAND, THE EXACT LOCATION OF WHICH CAN BE DETERMINED BY EXAMINATION OF THE ABOVE-MENTIONED INSTRUMENT, WHICH CONTAINS A COMPLETE LEGAL DESCRIPTION OF THE AFFECTED PORTIONS OF SAID LAND.

LIMITATIONS ON THE USE, BY THE OWNERS OF SAID LAND, OF THE EASEMENT AREA AS SET FORTH IN THE EASEMENT DOCUMENT SHOWN HEREIN ABOVE.

REFERENCE IS HEREBY MADE TO SAID DOCUMENT FOR FULL PARTICULARS.

SAID OFFER WAS ACCEPTED BY RESOLUTION, A CERTIFIED COPY OF WHICH WAS RECORDED APRIL 12, 1989 AS INSTRUMENT NO. 89- 567553 OF OFFICIAL RECORDS.

MATTERS AFFECTING PARCEL, H NOT LISTED HEREON ARE NOT EASEMENT ITEMS AND/OR ARE BLANKET IN NATURE

MATTERS AFFECTING PARCELS I & J NOT LISTED HEREON ARE NOT EASEMENT ITEMS AND/OR ARE BLANKET IN NATURE

PROJECT NOTES

SITE ADDRESS: 6236-6334 WEST YUCCA STREET; 1745-1773 NORTH VINE STREET; 1733-1741 ARGYLE AVENUE, LOS ANGELES, CA 90028

APN: 5546-004-006, 020, 021, 029 & 032; 5546-030-028, 031, 032, 033 & 034

DISTRICT MAP: 150A187

THOMAS BROS. GUIDE: 593-F-4

THE SUBJECT SITE IS IN FEMA FLOOD HAZARD ZONE "X", NOT SUBJECT TO INUNDATION OR STORM WATER OVERFLOWS, PER PANEL NO. 06037C1605F WITH EFFECTIVE DATE OF 09-26-2008.

ELEVATIONS SHOWN HEREON ARE FROM FIELD SURVEY PERFORMED NOVEMBER, 2016 AND FEBRUARY, 2018.

PROJECT CONSISTS OF 3 GROUND LOTS AND 35 AIRSPACE LOTS.

THE SITE DOES NOT CONTAIN ANY PROTECTED TREES. REFER TO TREE REPORT BY CARLBERG ASSOCIATES DATED MARCH 28, 2018 FOR FULL INVENTORY.

STREET DESIGNATIONS: YUCCA STREET (WEST OF VINE) - AVENUE II
YUCCA STREET (EAST OF VINE) - LOCAL STREET - STANDARD
VINE STREET - AVENUE II
IVAR AVENUE - LOCAL STREET - STANDARD
ARGYLE AVENUE - LOCAL STREET - STANDARD

COMMUNITY PLAN: HOLLYWOOD

GENERAL PLAN DESIGNATION: EXISTING: REGIONAL CENTER COMMERCIAL
PROPOSED: REGIONAL CENTER COMMERCIAL

SPECIFIC PLAN AREA: NONE

EXISTING UTILITIES: UNDERGROUND UTILITIES SHOWN HEREON WERE OBTAINED FROM CITY SUBSTRUCTURE MAPS OBTAINED ON THE NAVIGATE LA WEBSITE. CERTAIN UTILITIES SUCH AS TRAFFIC SIGNAL LINES AND ABANDONED LINES MAY NOT BE SHOWN HEREON.

PROPOSED UTILITIES: SEWAGE AND DRAINAGE WILL BE PROVIDED BY THE CITY OF LOS ANGELES INFRASTRUCTURE SYSTEMS.

LOT CONFIGURATIONS AND SIZES ARE APPROXIMATE IN NATURE AND WILL BE FINALIZED DURING THE FINAL MAP PHASE.

WE RESERVE THE RIGHT TO CONSOLIDATE LOTS.

WE RESERVE THE RIGHT TO PHASE FINAL MAPS.

FINAL ELEVATION AND HORIZONTAL LIMITS FOR AIRSPACE LOTS TO BE DETERMINED BY APPROVED ARCHITECTURAL PLANS.

ZONING

EXISTING: (T)C2-2-SN; C4-2D-SN

PROPOSED: C2-2-SN

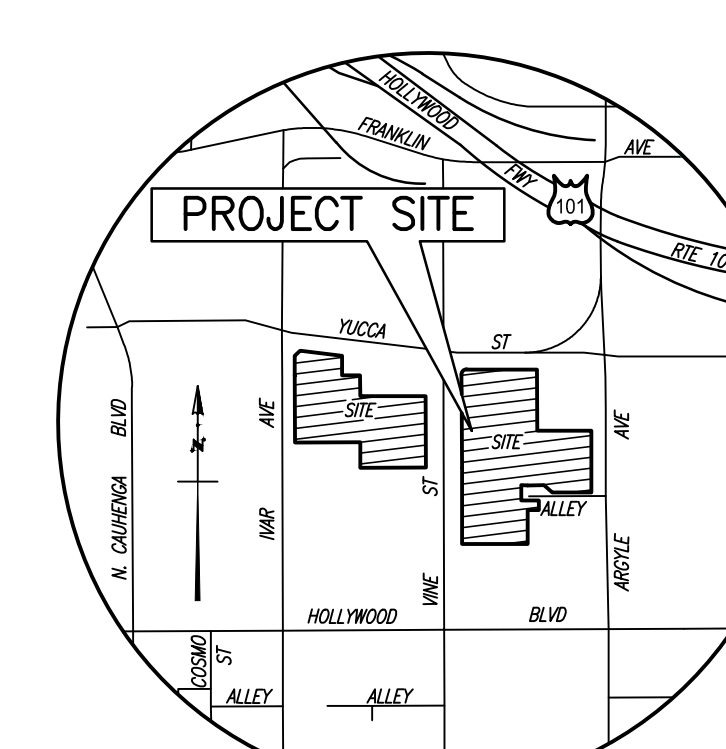

VICINITY MAP NOT TO SCALE

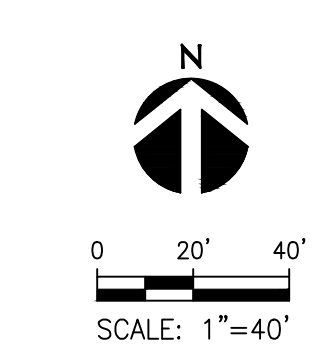

PREPARED UNDER THE DIRECTION OF:

For Review 04/10/2018

CHRISTOPHER JONES, LS 8193

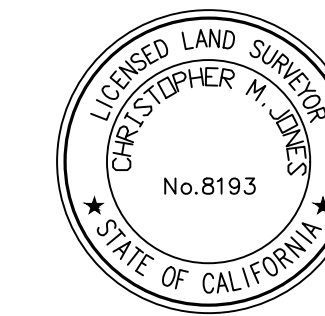

700 South Flower Street Suite 2100 Los Angeles, CA 90071 O: 213.418.0201 F: 213.266.5294 www.kpff.com

GENERAL NOTES:

OWNER:

1749 NORTH VINE, LLC 350 SOUTH GRAND AVE., 25TH FLOOR LOS ANGELES, CA 90071 (213) 229-9548 ATTN: EDGAR KHALATIAN

SUBDIVIDER:

MCAF VINE, LLC 350 SOUTH GRAND AVE., 25TH FLOOR LOS ANGELES, CA 90071 (213) 229-9548 ATTN: EDGAR KHALATIAN

LAND SURVEYOR:

KPFF CONSULTING ENGINEERS, INC. 700 S. FLOWER ST., SUITE 2100 LOS ANGELES, CA 90071 (213) 418-0201 ATTN: CHRISTOPHER JONES, PLS 8193

Table with 2 columns: REVISIONS, ISSUED FOR. Includes a triangle symbol in the second row.

Table with 2 columns: DATE, PROJECT NUMBER, DRAWN BY, CHECKED BY, SCALE. Values include 4/10/2018, 1700080, JP, CJ, AS SPECIFIED.

PROJECT ADDRESS: HOLLYWOOD CENTER

SHEET NUMBER

SHEET 1 OF 4

# VESTING TENTATIVE TRACT MAP NO. 82152

## AIRSPACE LOT CONFIGURATIONS

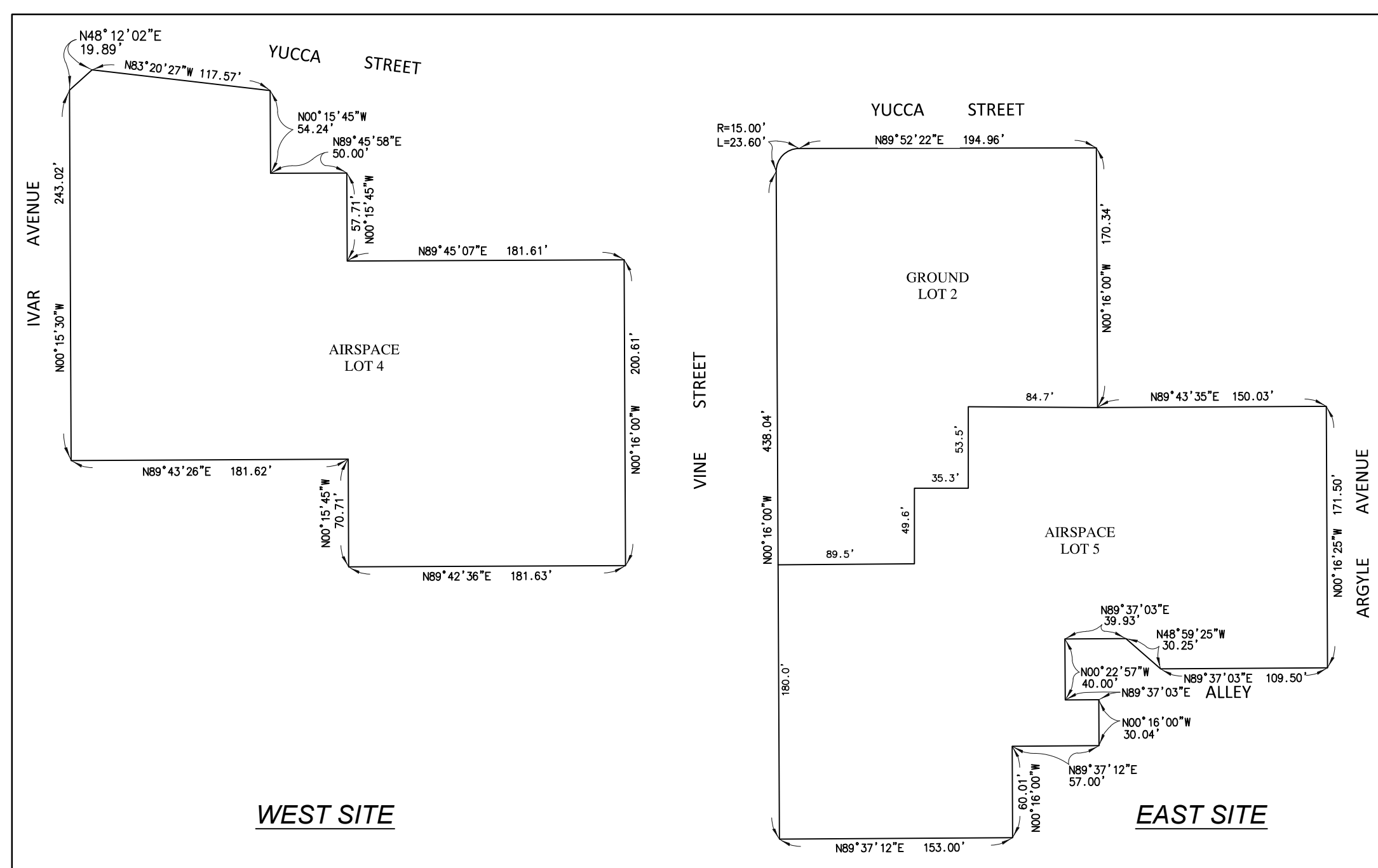

**LEVELS B5 - B3**  
L.E. = -84.00', U.E. = -22.00'

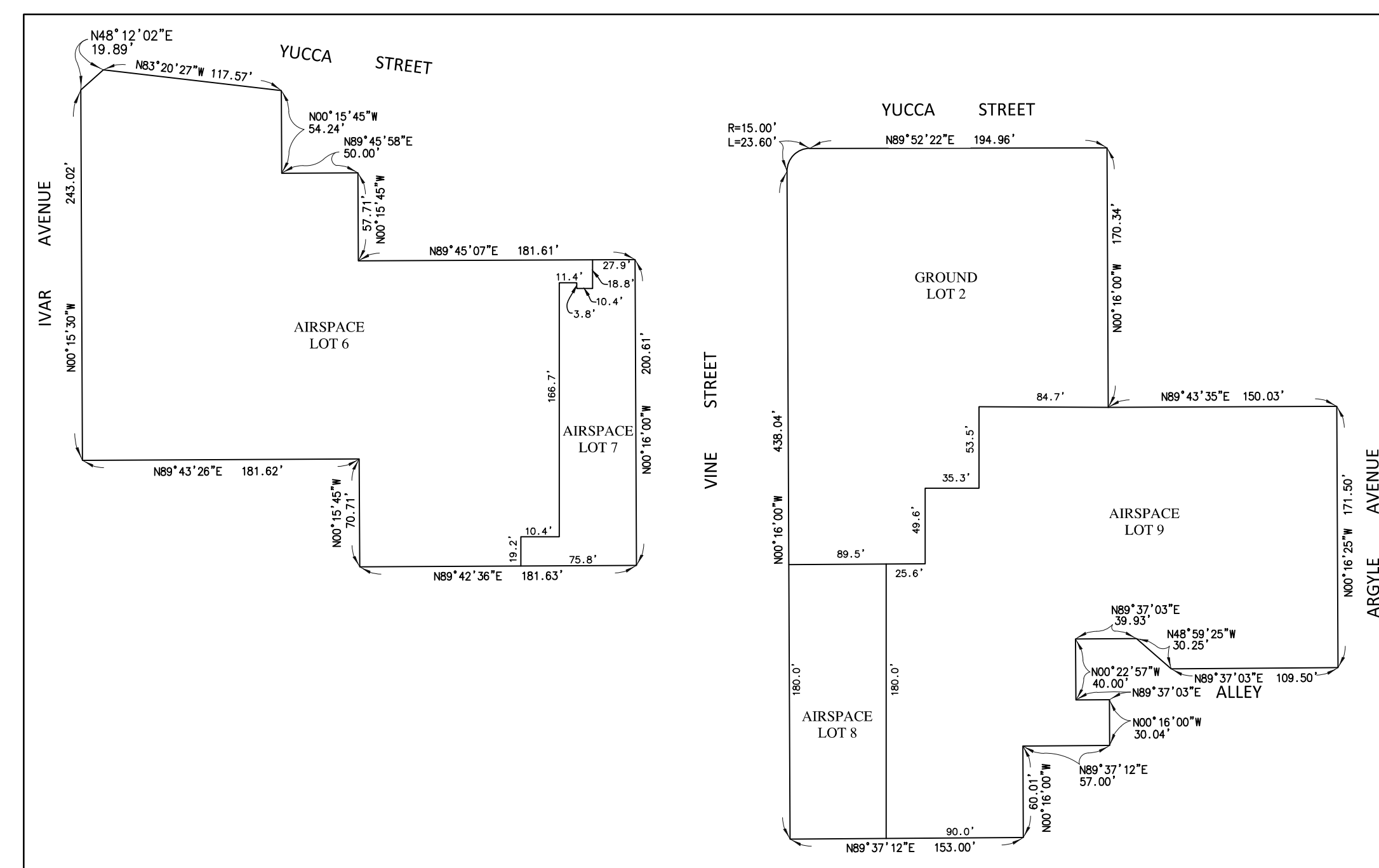

**LEVEL B2**  
L.E. = -22.00', U.E. = -11.00'

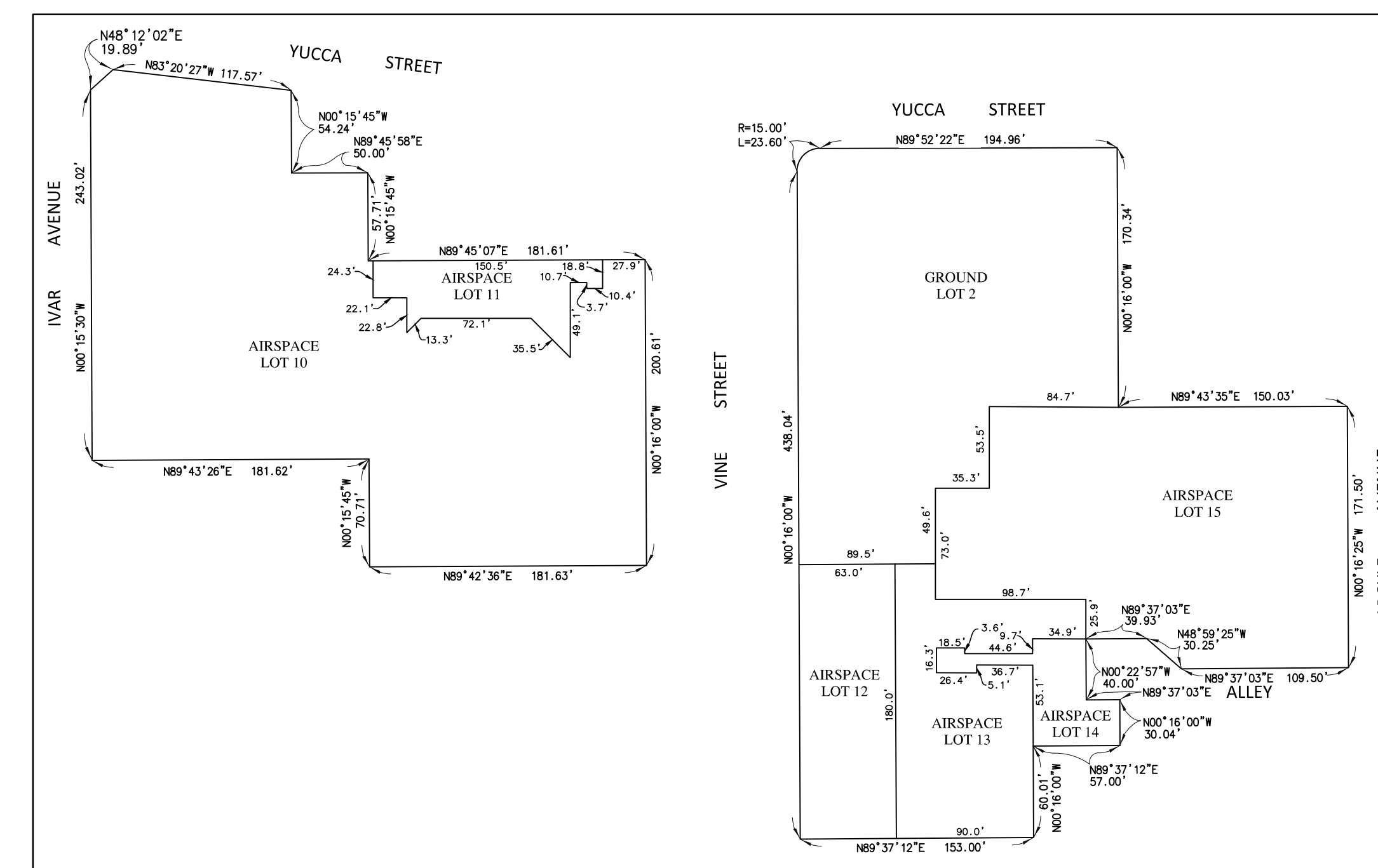

**LEVEL B1**  
L.E. = -11.00', U.E. = 00.00'

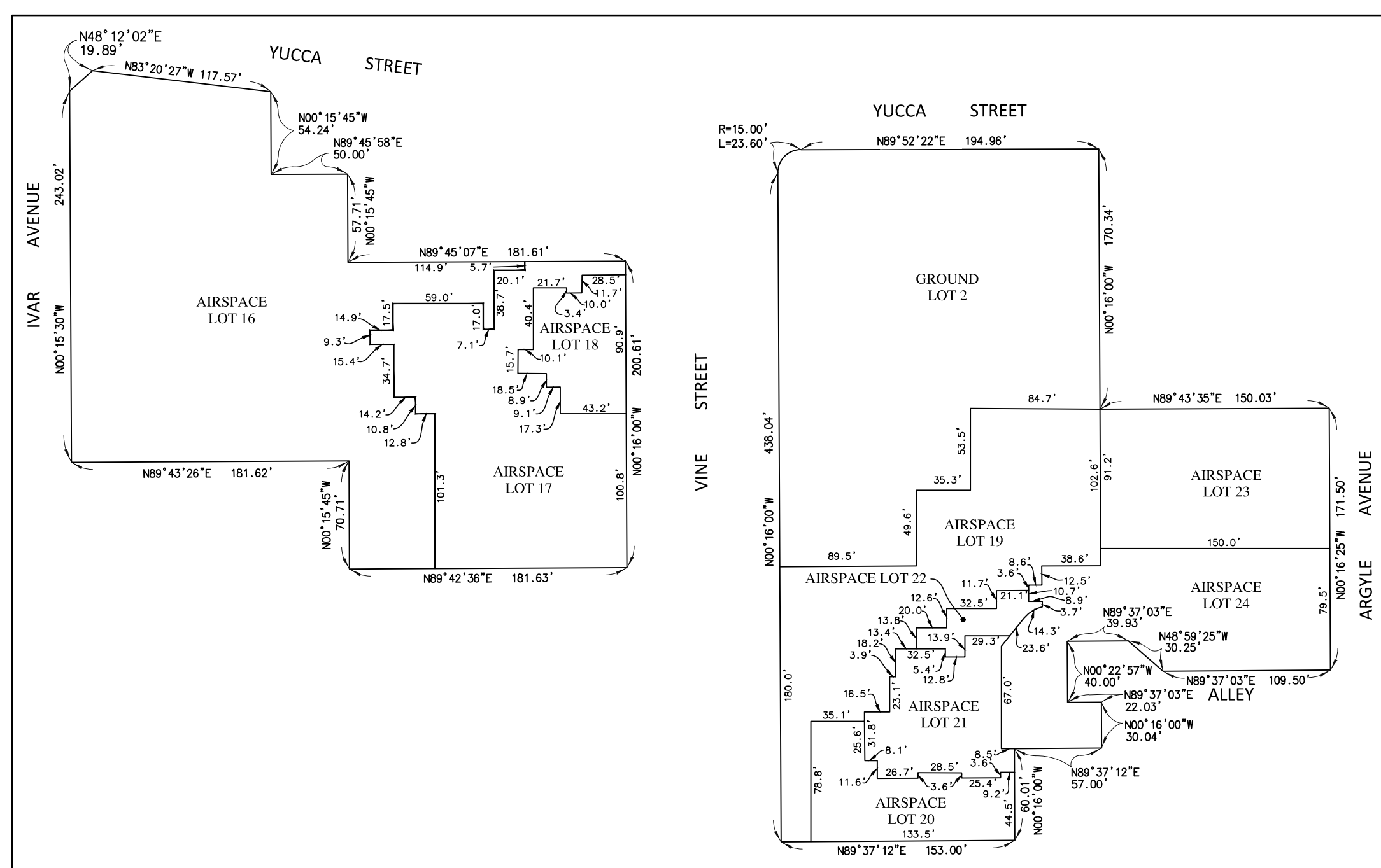

**LEVEL 01**  
L.E. = 00.00', U.E. = 15.00'

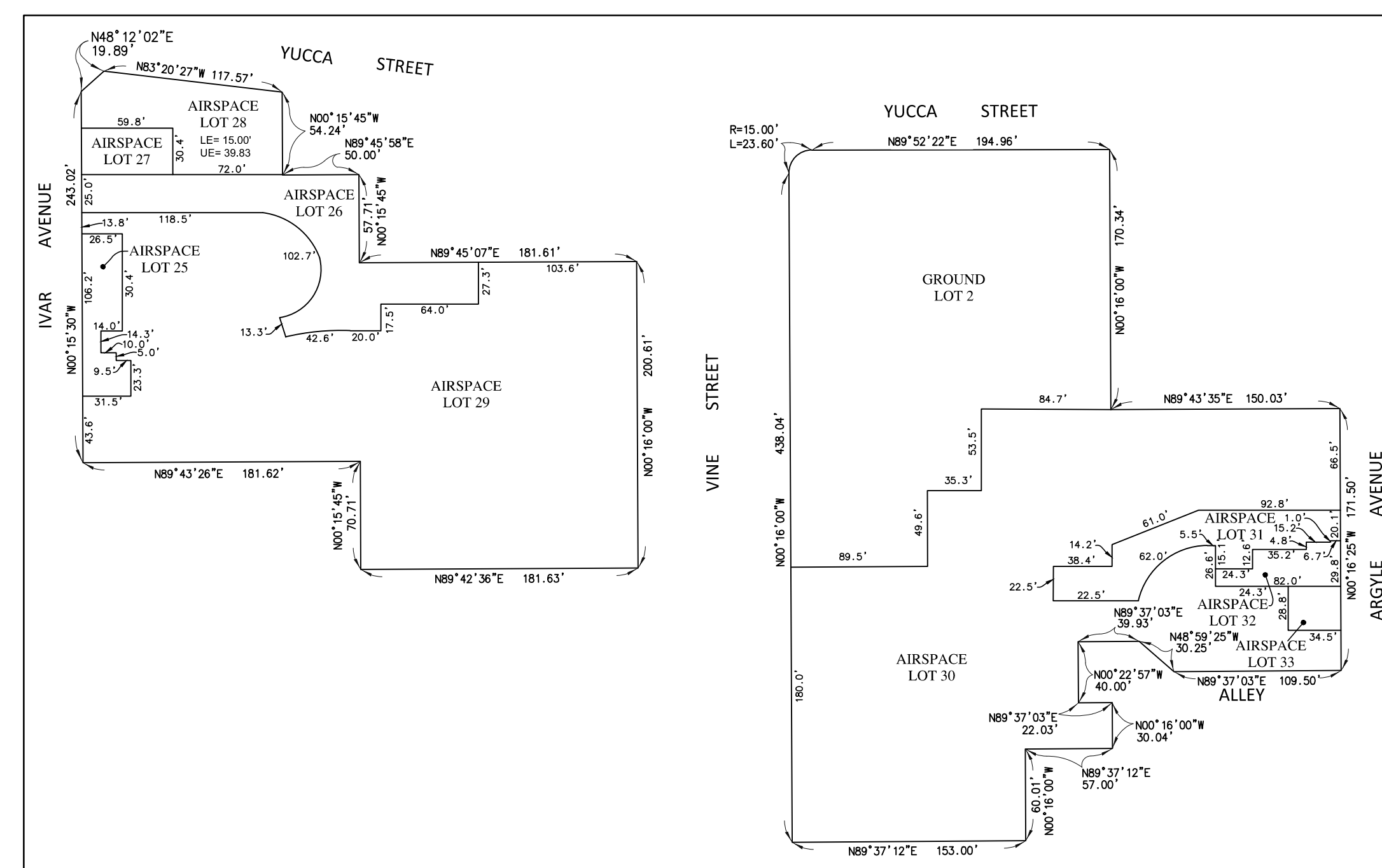

**LEVEL 01 (MEZZ)**  
L.E. = 15.00', U.E. = 30.00'

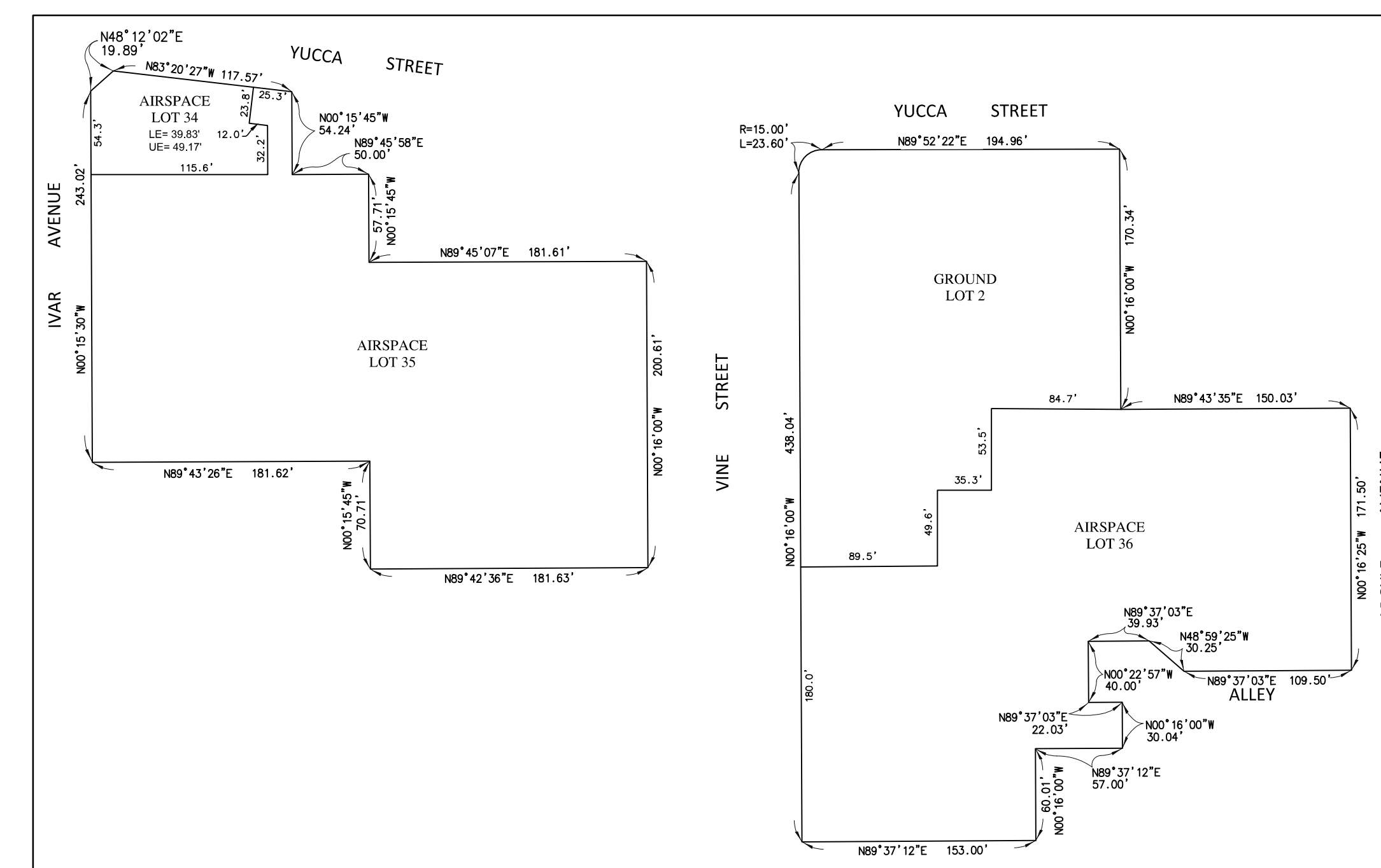

**LEVEL 02**  
L.E. = 30.00', U.E. = 41.25'

NOTE:  
GROUND LOTS SHOWN FOR LOCATION/REFERENCE ONLY.  
NO AIRSPACE LOTS WITHIN GROUND LOT 2.

**ABBREVIATION LEGEND**  
L.E. = LOWER ELEVATION  
U.E. = UPPER ELEVATION

REVISIONS	DATE	ISSUED FOR

DATE: 04/10/2018  
PROJECT NUMBER: 1700080  
DRAWN BY: JP  
CHECKED BY: CJ  
SCALE: AS SPECIFIED  
PROJECT ADDRESS:  
**HOLLYWOOD CENTER**

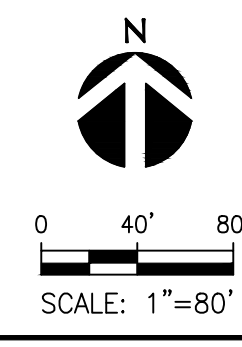

# VESTING TENTATIVE TRACT MAP NO. 82152

## AIRSPACE LOT CONFIGURATIONS

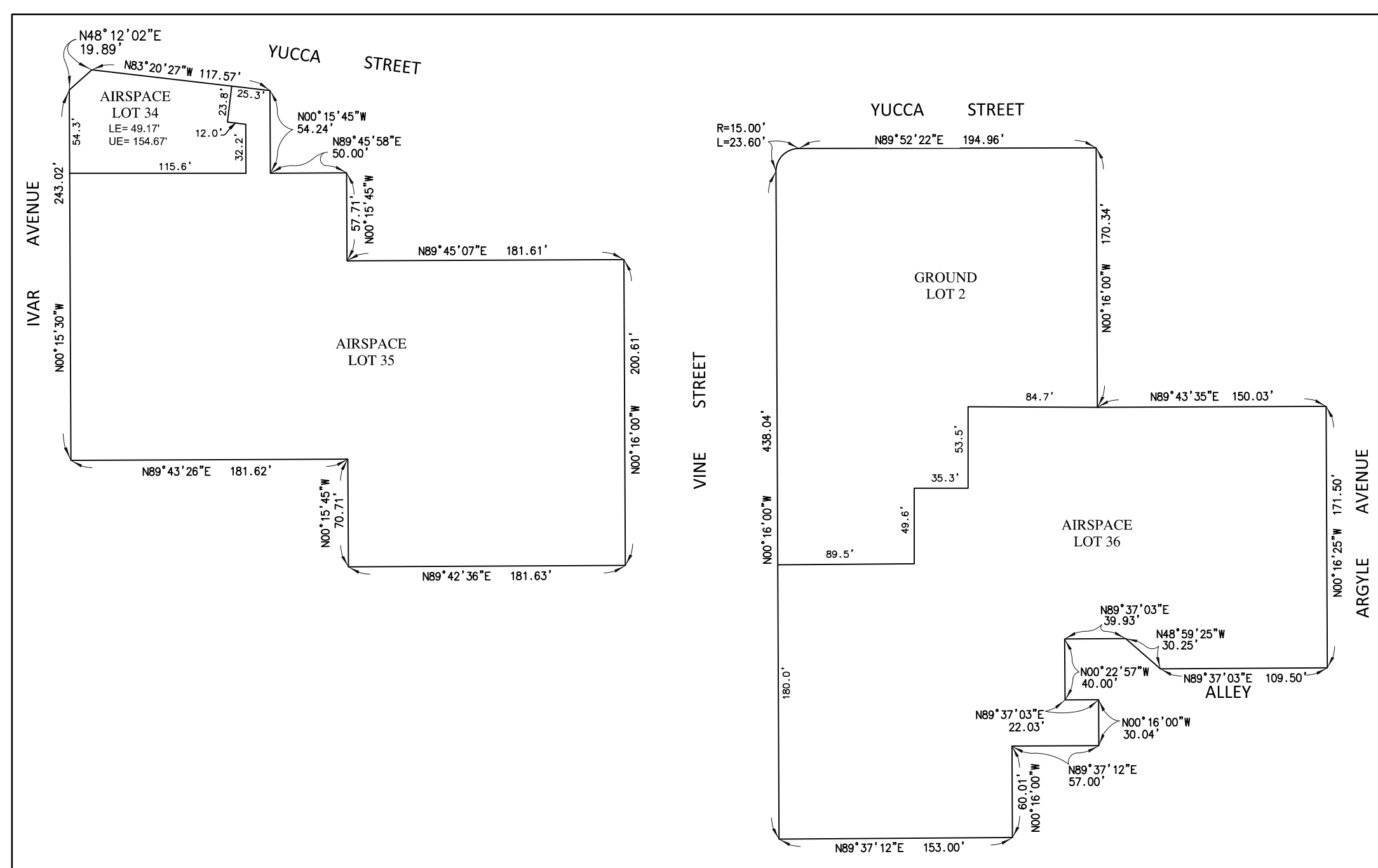

**LEVELS 03 - 20**  
L.E. = 41.25', U.E. = 245.25'

**LEVELS 03 - 06**  
L.E. = 46.00', U.E. = 90.00'

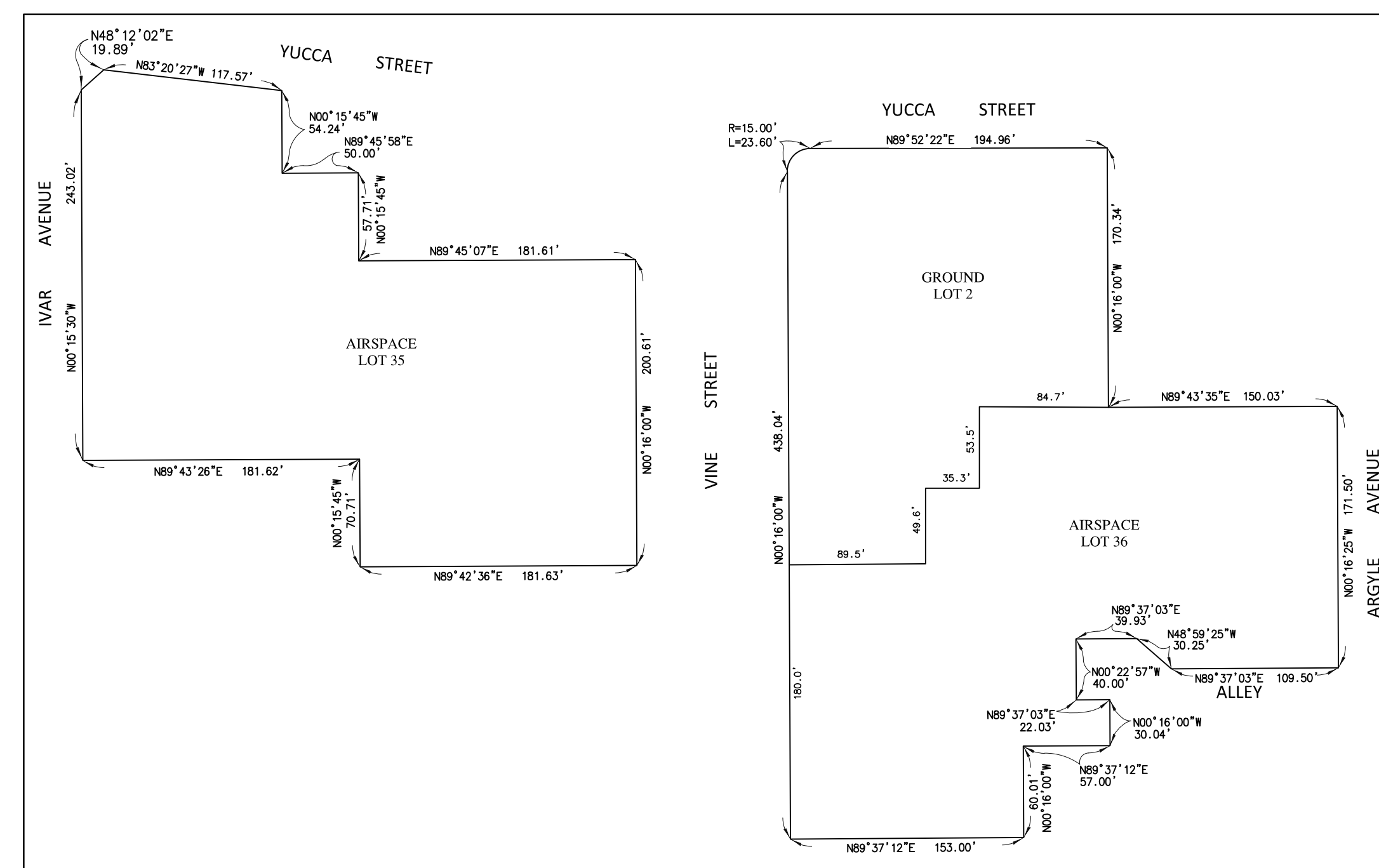

**LEVEL 21**  
L.E. = 245.25', U.E. = 257.25'

**LEVELS 07 - 29**  
L.E. = 90.00', U.E. = 343.00'

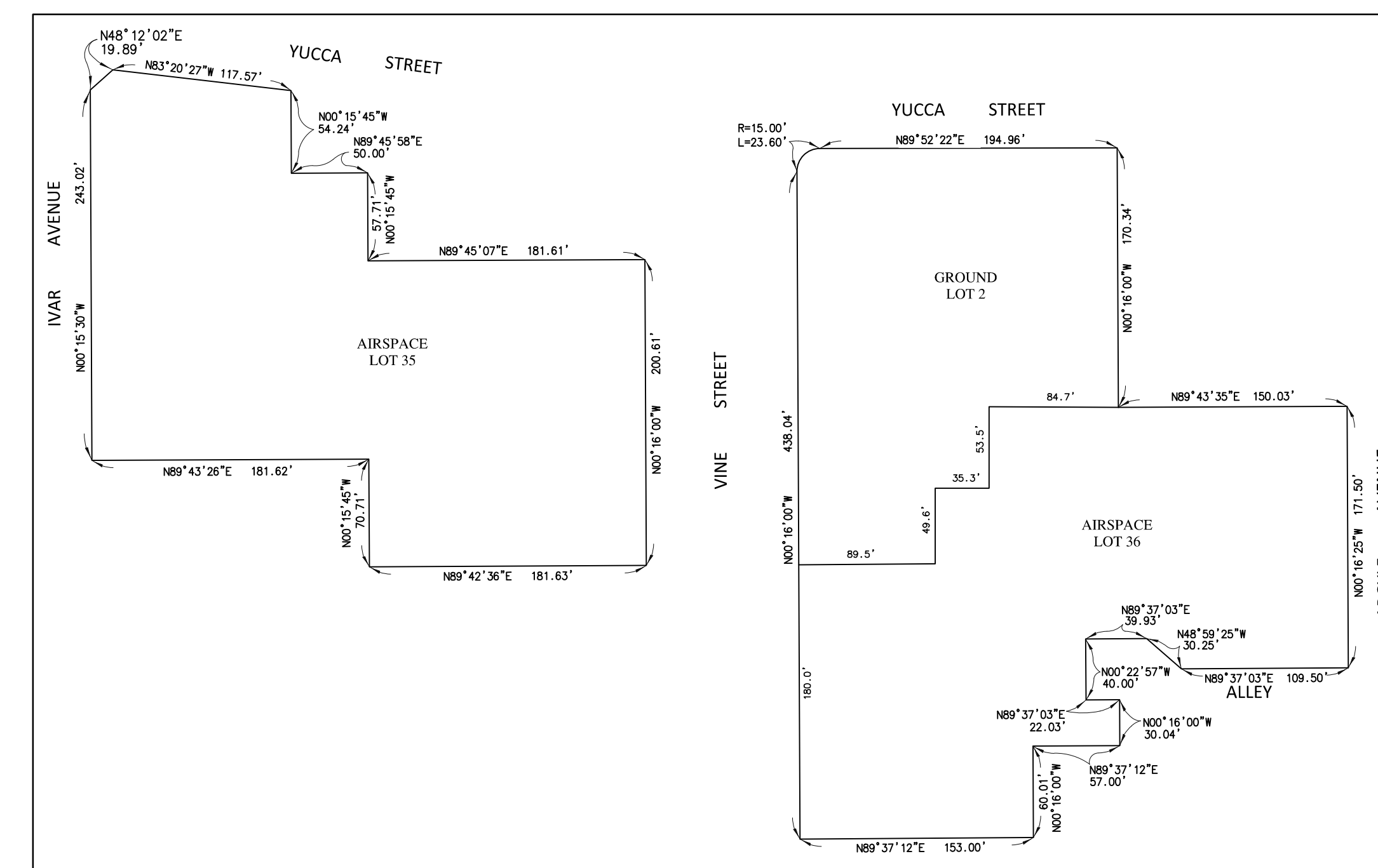

**LEVELS 22 - 34**  
L.E. = 257.25', U.E. = 413.25'

**LEVEL 30**  
L.E. = 343.00', U.E. = 354.58'

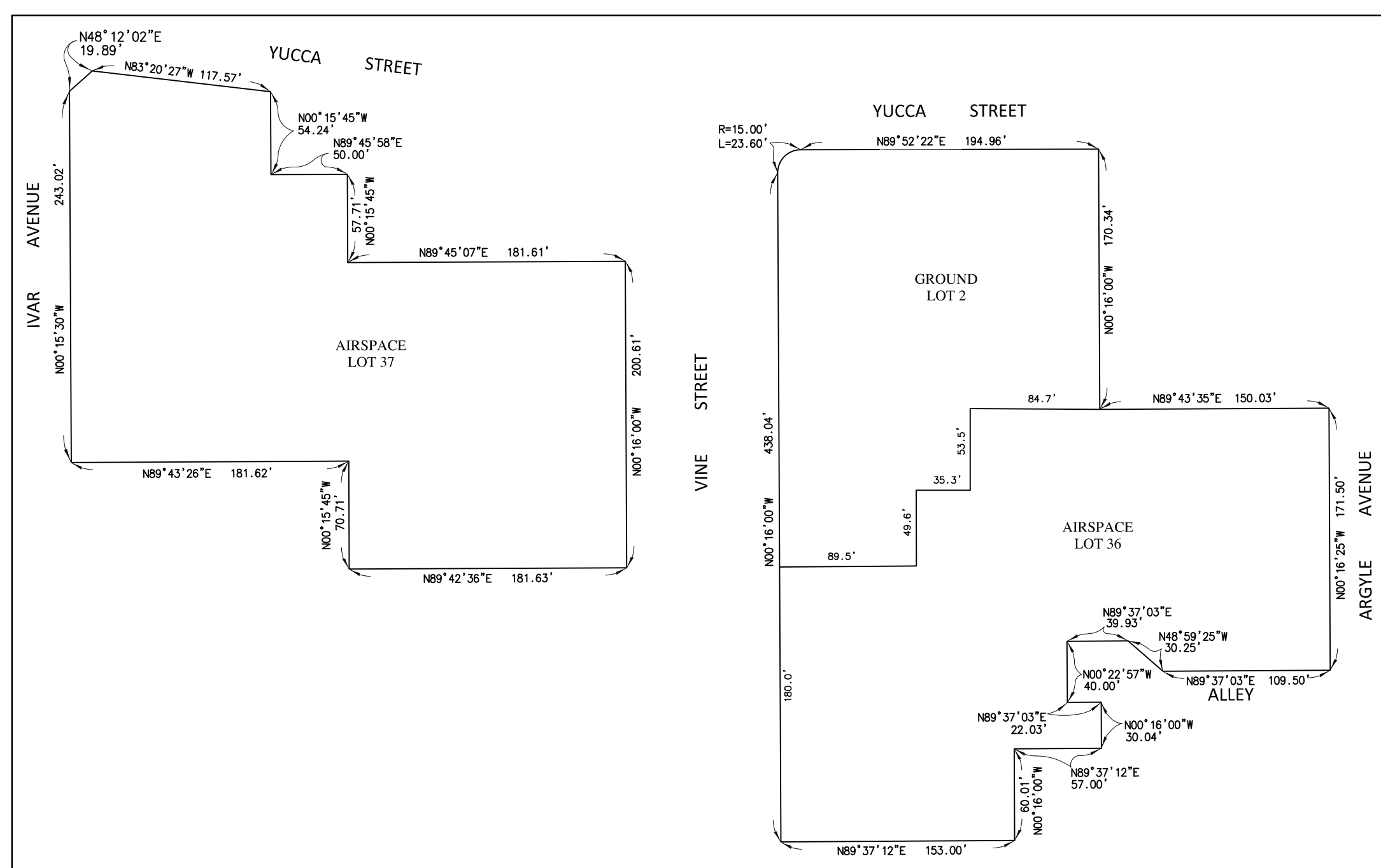

**LEVELS 35 - ROOF+**  
L.E. = 413.25', U.E. = 519.00'

**LEVELS 31 - 45**  
L.E. = 354.58', U.E. = 528.25'

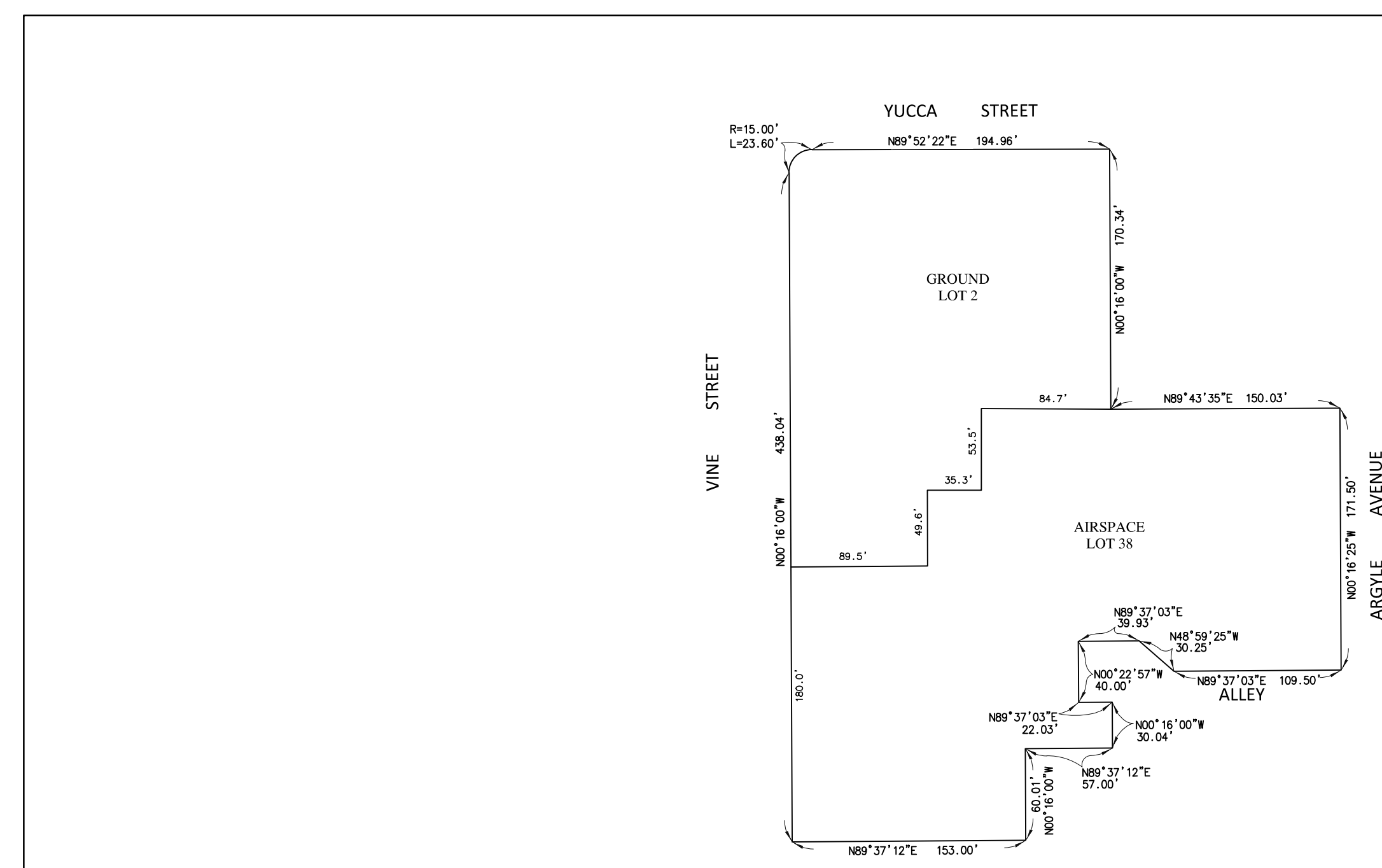

**LEVELS 46 - ROOF+**  
L.E. = 528.25', U.E. = 645.00'

NOTE:  
GROUND LOTS SHOWN FOR LOCATION/REFERENCE ONLY.  
NO AIRSPACE LOTS WITHIN GROUND LOT 2.

**ABBREVIATION LEGEND**

L.E. = LOWER ELEVATION  
U.E. = UPPER ELEVATION

REVISIONS	DATE	ISSUED FOR

DATE	04/10/2018
PROJECT NUMBER	1700060
DRAWN BY	JP
CHECKED BY	CJ
SCALE	AS SPECIFIED

PROJECT ADDRESS  
**HOLLYWOOD CENTER**

SHEET NUMBER

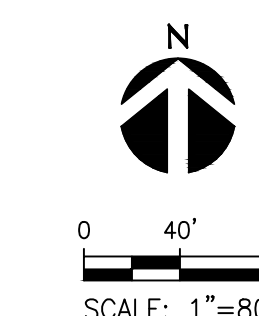

# VESTING TENTATIVE TRACT MAP NO. 82152

## AIRSPACE LOT ISOMETRIC

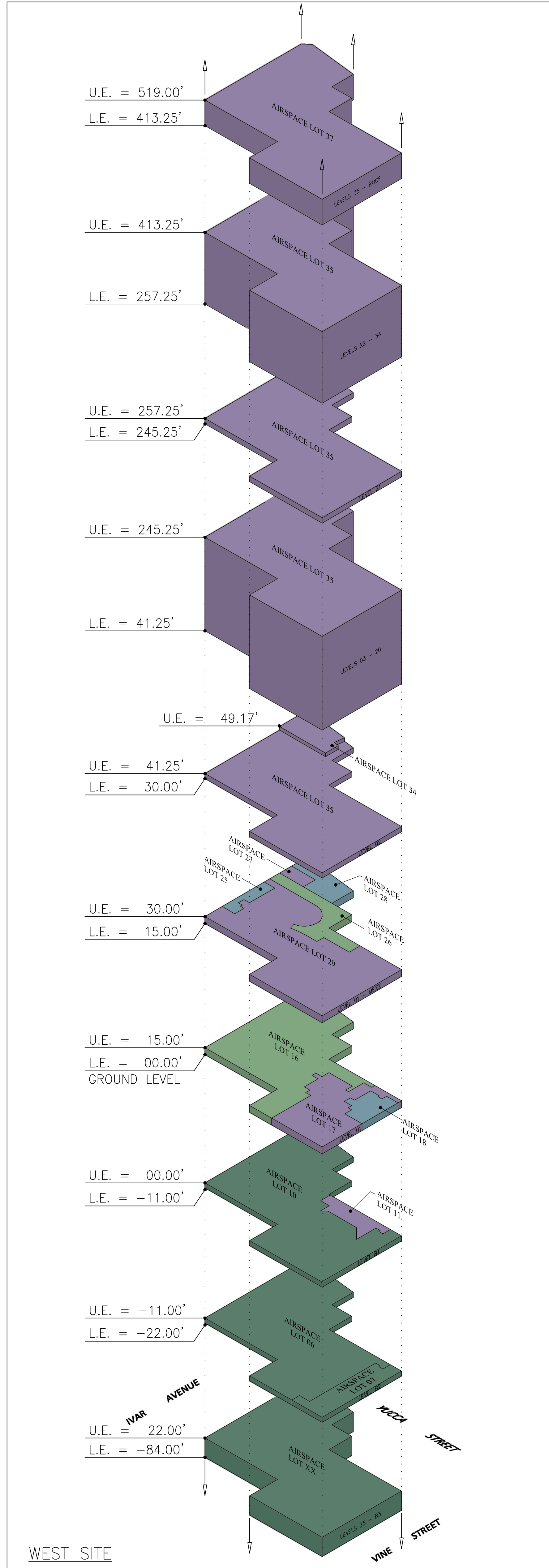

FLOOR VIEWS

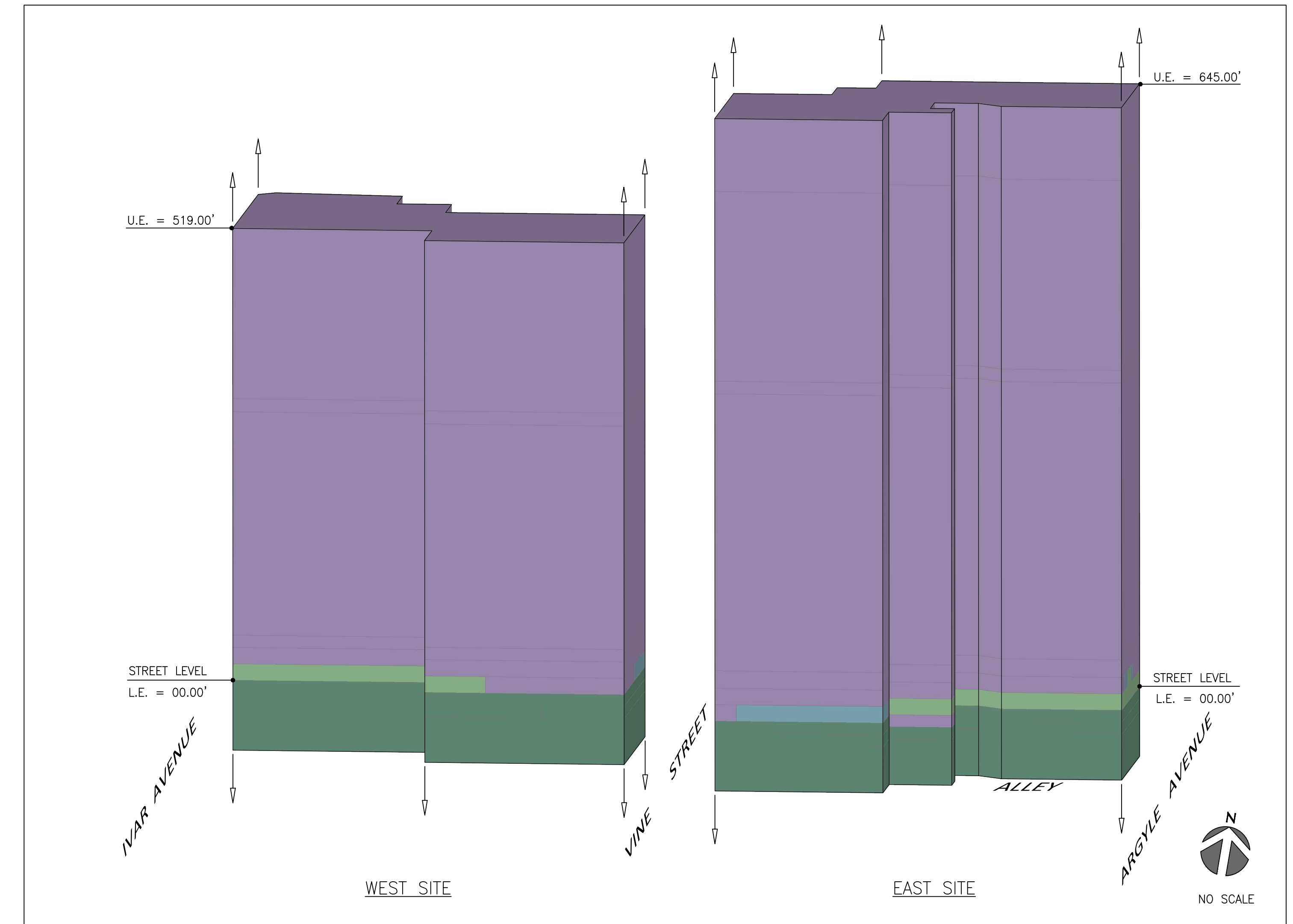
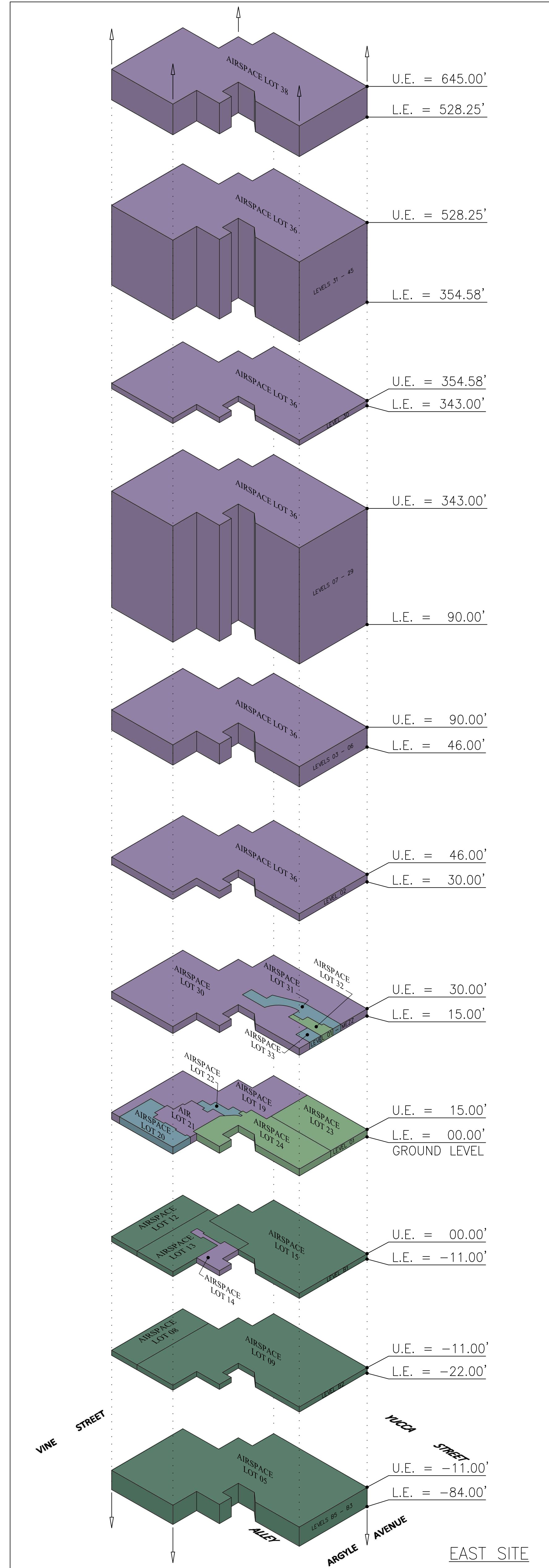

OVERALL VIEW  
LOOKING NORTH

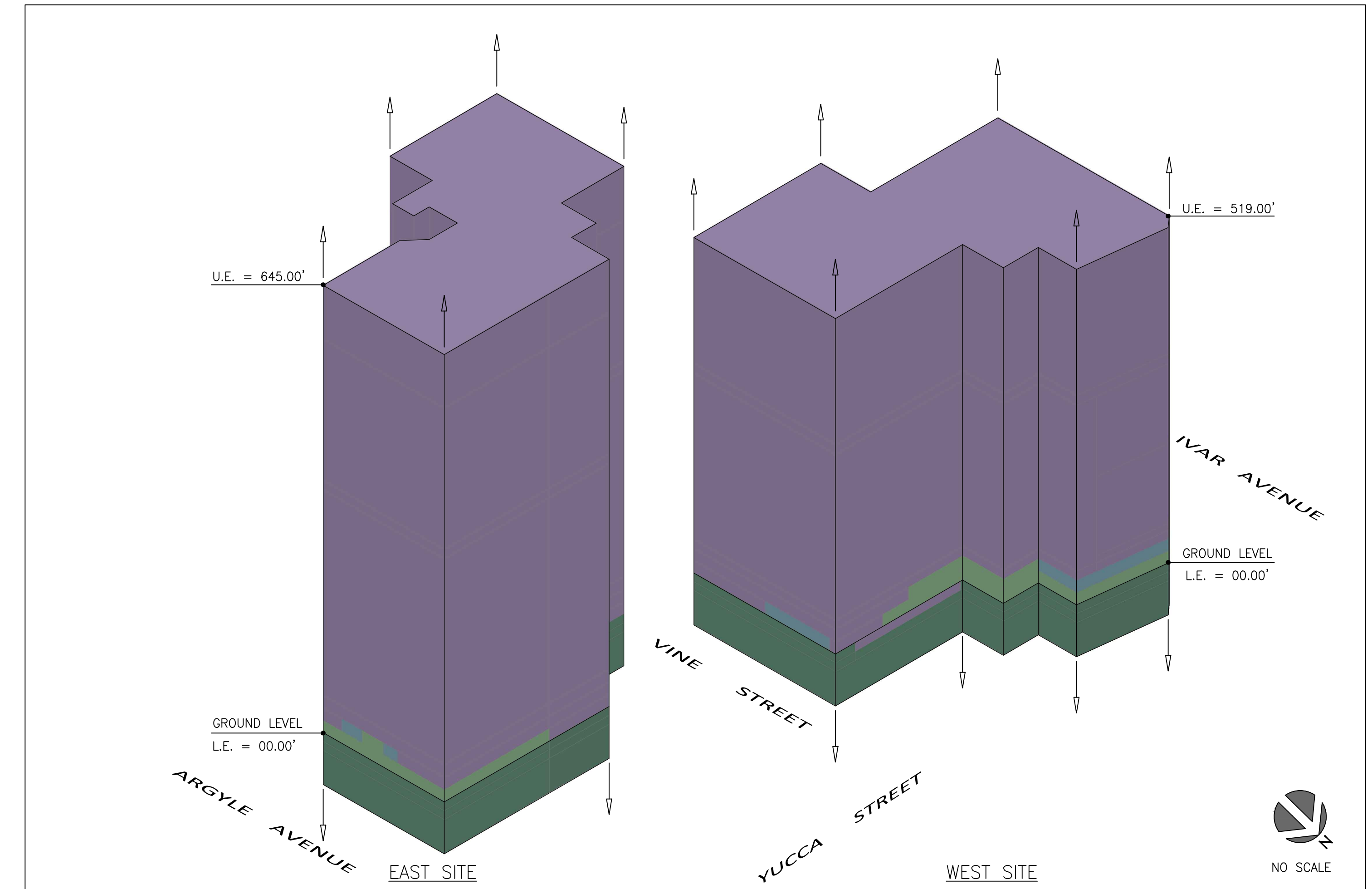

OVERALL VIEW  
LOOKING SOUTHWEST

**ABBREVIATION LEGEND**  
L.E. = LOWER ELEVATION  
U.E. = UPPER ELEVATION

REVISIONS	
DATE	ISSUED FOR

DATE	04/10/2018
PROJECT NUMBER	1700060
DRAWN BY	JP
CHECKED BY	CJ
SCALE	AS SPECIFIED

PROJECT ADDRESS  
**HOLLYWOOD CENTER**

SHEET NUMBER